

TURBBAUM HEBETECHNIK

2.25 SL

date: June 24th 1996

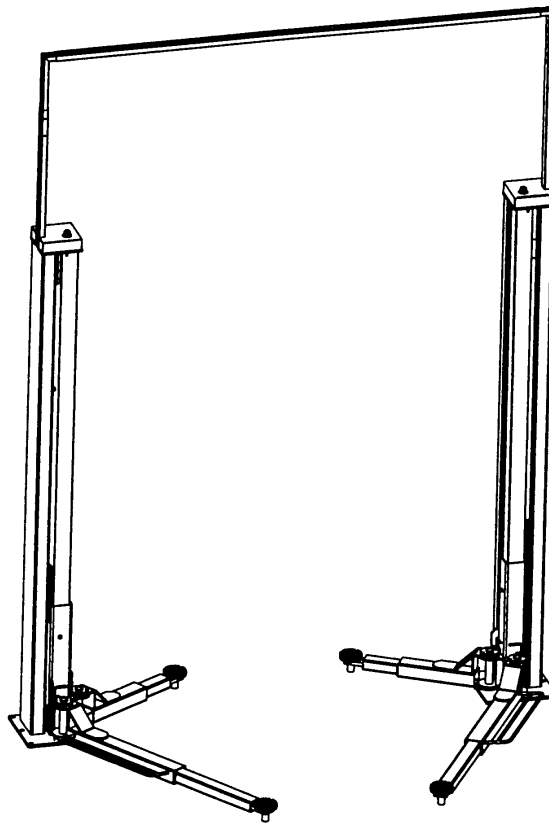

Operating instruction and documentation

serial-number.....

Table of contents

Record of installation.....	3
Record of handing over.....	4
1. Introduction.....	5
2. Master document of the lift.....	6
Page for notices.....	7
3. Technical information.....	8
Data sheet 2.25 SL.....	9
Foundation plan.....	10
Block foundation plan.....	11
Electrical diagram drawing part 1.....	12
Electrical diagram drawing part 2.....	13
Parts list of electrical diagram.....	14
4. Safety regulations.....	15
5. Operating instruction.....	15
6. Troubleshooting.....	17
7. Maintenance.....	19
adjusting of the Polyflex-belt.....	21
8. Security-check.....	23
9. Installation and initiation.....	25
Installation of the lift.....	25
Erection and doweling of the lift.....	26
Electrical installation of the lift.....	27
Installation of the control-rope.....	29
Installation of the carrying arms.....	33
Initiation.....	33
Changing of the installation place.....	34

Appendix

Document "First security check before Installation"

Document "Regular security check"

Document "Extraordinary security check"



Send this record, filled in and undersigned, to the automotive manufacturer after the installation

Otto Nußbaum GmbH & Co.KG

Korker Straße 24

777694 Kehl-Bodersweier

Germany

Record of installation

The automotive lift 2.25 SL with the

serial number.: was installed on

at the firm..... at.....

the safety was checked and the lift was startet.

The installation was effected from the operating authority / competent (please delete as applicable)

The safety of the automotive lift was checked from the competent before the initial operation

The operating authority attest the installation of the automotive lift, the competent attest the correct initial operation.

.....
date name of the operating authority signature of the operating authority

.....
date name of the competent signature of the competent

Record of handing over

The automotive lift 2.25 SL with the

serial number.: was installed on

at the firm..... at.....

the safety was checked and the lift was startet.

The persons below were introduced after the installation of the automotive lift. The introduction was carried out from an erector of the lift-manufacturer or from a franchised dealer (competent).

.....
date name signature

.....
date name signature

.....
date name signature

.....
date name signature

.....
date name signature

.....
date name of the competent signature of the competent

1. Introduction

The document "**Operating Instructions and Documentation**" contains important information about installation, running and preserving of the 2.25 SL.

To furnish proof of **installation of the automotive lift** the form "Record of Installation" must be sent undersigned to the manufacturer.

To furnish proof of the single, regular and special security checks this documentation contains forms. The forms should be used to document the checks. They should also be left in this documentation.

Every **Changes in the construction** and **changing place** of the automotive lift must be registered in the "Master document" of the lift.

Installation and check of the automotive lift

Only specialist staff is allowed to do the works concerning safety and to hold the safety checks of the lift. They are called experts and competents in this document.

Experts are persons (for example self-employed engineers, TÜV-experts) which have got an instruction and experience to check and to test automotive lifts in an expert's report. They know the signified regulations for protection of labour and prevention of accidents.

Competents are persons which have got enough knowledge and experience with automotive lifts. They took part in a training from the lift-manufacturer (servicing erectors of the manufacturer and the franchised dealer are Competents)

Information of danger

To show danger and to show important information the three symbols below with the special meanings are used. Pay attention of those passages, which are marked with these symbols



Danger!

This sign marks a danger to life. Inexpert handling of the marked series of event ist dangerous to life



Caution!

This sign marks a caution against possible damage of the automotive lift or other material defects in case of inexpert handling .



Indication!

This sign marks an indication for an important function or for another important note.

2. Master document of the automotive lift

Lift designation 2.25 SL
Lift-manufacturer Otto Nußbaum GmbH & Co.KG
Korker Straße 24
77694 Kehl-Bodersweier
Germany

Application

The automotive lift 2.25 SL is a lifting stage for lifting and repairing vehicles with a laden weight of 2500 kg. The load of one carrying arm must not be more than 750 kg. It's not allowed to put the load only on one of the carrying arms, just as it is not allowed to install the lift in rooms with danger of explosion.

After changing construction and after reparings the lift has to be checked from an expert again. The operating instruction and the instruction for maintenance have to be observed.



Changes of construction, reparings and changes of place must be registered in this master document

Changes of the construction, expert checking, resumption of work (date, kind of change, signature of the expert)

.....
.....
.....

.....
name, address of the expert

.....
place, date

.....
signature of the expert

Change of automotive-lift-place, expert checking, resumption of work (date, address and signature of the competent)

.....
name, address of the competent

.....
place, date

.....
signature of the competent

CE-certificate/attestation of conformity

The automotive lift 2.25 SL with the serial number
is in accordance with the tested lift (number 04 205-2561/96)

.....
place, date.....
company stamp, signature**ZERTIFIKAT
CERTIFICATE****RWTÜV**

ANLAGENTECHNIK GMBH

Registrier-Nr./Registered No.:

04 205-2561/96**EG-Baumusterprüfbescheinigung gemäß Anhang VI der EG-Richtlinie 89/392/EWG**
EC-type approval according to appendix VI of the EC-directive 89/392/EEC

Zeichen des Auftraggebers Reference of applicant	Auftragsdatum Date of application	Attenzeichen File reference	Prüfbericht Nr. Test report No.	Ausstellungsdatum Date of issue	Gültigkeit bis Expiry date:
Hr. Müller	27.03.1996	7.2-718/96	2558/96 + 2559/96	22.08.1996	22.08.2001

Hiermit wird bestätigt, daß das nachfolgend genannte Produkt den grundlegenden Anforderungen der Richtlinie des Rates vom 14.06.89 zur Angleichung der Rechtsvorschriften der Mitgliedstaaten über Maschinen, sowie den Änderungen 91/368/EWG und 93/44/EWG, entspricht.

We hereby certify that the product mentioned below meets the basic requirements of the council directive dated 14.06.89 on the approximation of the laws of the member states relating to machinery, as well as the amendments 91/368/EEC and 93/44 EEC.

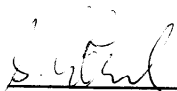
CE 0044**Antragsteller** Otto Nußbaum GmbH & Co. KG
Applicant: Korker Str. 24, D-77694 Kehl**Fertigungsstätte:** s. o.
Manufacturing plant:**Produktbeschreibung:** Kfz-Hebebühne Typ: 2.25 SL
Product description:
TÜV CERT - Zertifizierungsstelle
der RWTÜV Anlagentechnik
im Institut für Gerätesicherheit und
Medizintechnik, notifiziert bei der EG-
Kommission unter Nr. 0044RWTÜV Anlagentechnik GmbH
Institut für Gerätesicherheit
und Medizintechnik
Langemarckstr. 20
D-45141 Essen
Tel.: (49) 201-825-3218
Fax: (49) 201-825-3209

3. Technical information

Technical ratings:

Lifting capacity 2.25 SL:	2500kg
Lifting capacity of one carrying arm 2.25 SL:	max. 750 kg; It's not allowed to put the load only on one of the carrying arms
Lifting time:	appr. 40 sec
max. height of lifting:	1870mm
Line voltage:	400 V three phase current
Driving voltage:	230 V
Power rating:	2 * 2,0 kW
Motor speed:	1350 revolution/minute
Sound level:	75 dBA

Safety devices

1. Safety switching in case the carrying nut breaks
check of the carrying nut with built-in pin
2. Limit switches for top and lowest position
Safety device of the lift against too much lifting or lowering of the carriage
3. foot protector
Safety device of the lift against squashing in case of unauthorized lowering of the lift.

Data sheet 2.25 SL

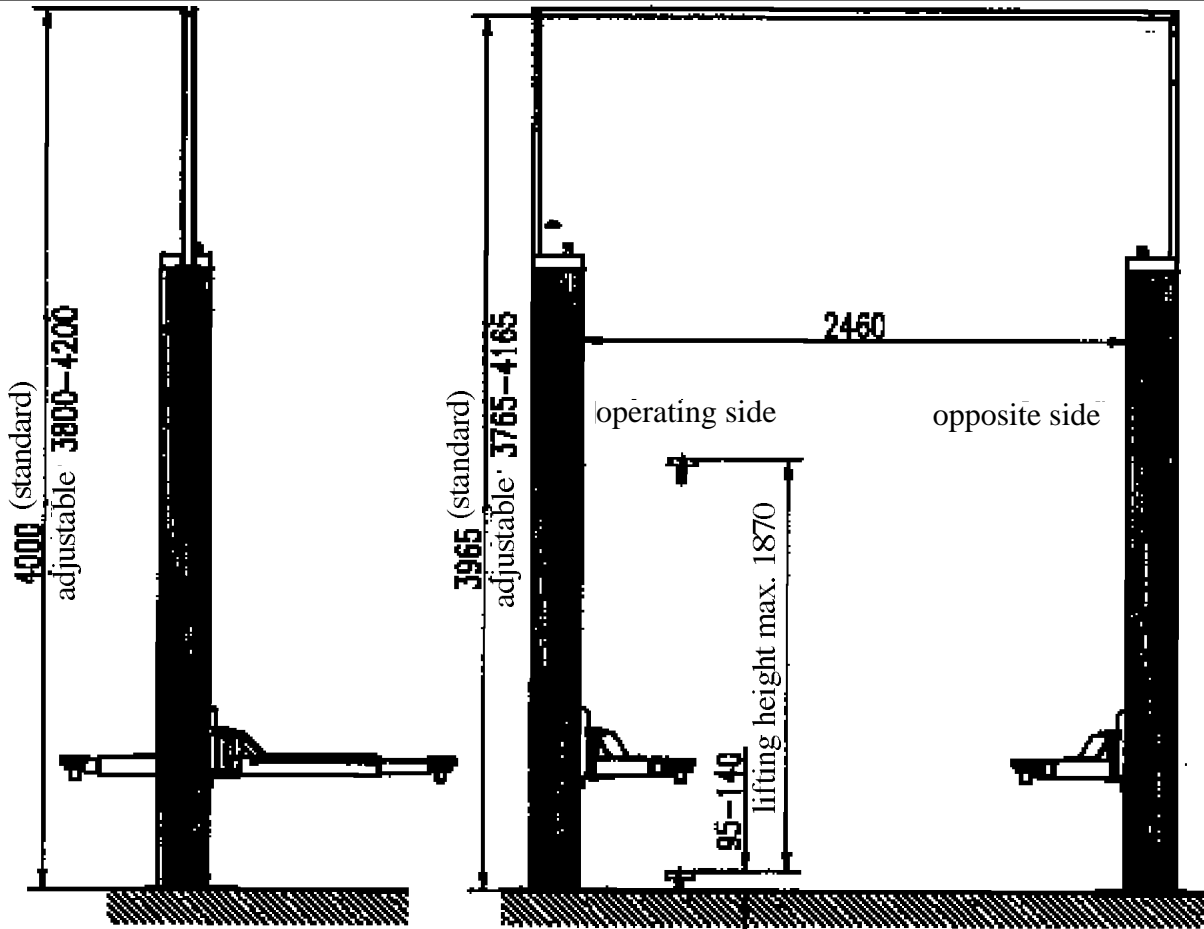

lifting capacity : 2500 kg
 lifting time : ca. 40 sec
 lowering time : ca. 40 sec
 power rating : 2 x 2,0 kW
 lifting height : 1870 mm

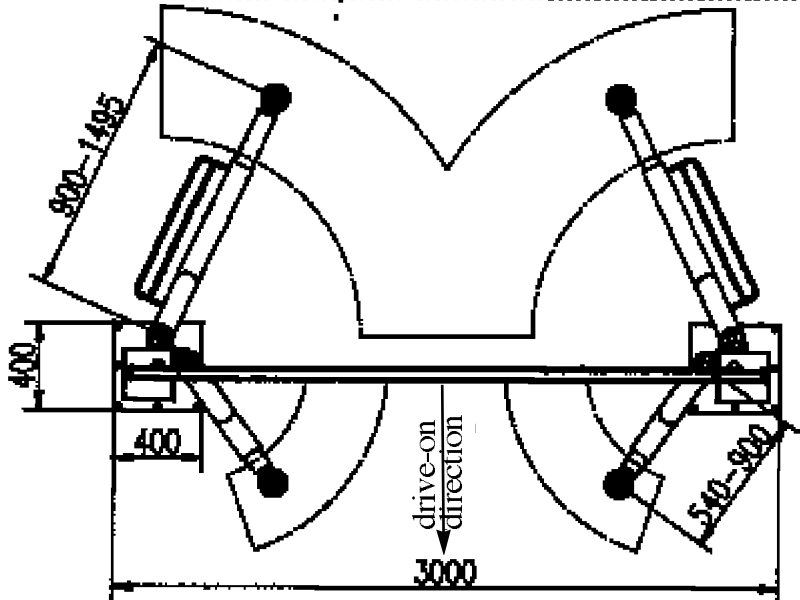

Änder- und Konstruktions-
änderungen vorbehalten

DIESE ZEICHNUNG WURDE AUF CAD ERSTELLT /

THIS DRAWING WAS CREATED ON A CAD SYSTEM

2-columns lift 2.25 SL

scale 1:30

TUPBAUM HEBETECHNIK

TEL. 07141/200-0 FAX 07141/200-100
 FÜRSTENBERGER STR. 100
 77694 KEHL-BODERSWEIER

23.04.1996 / VEID

EINBAU1370-1

Foundation plan

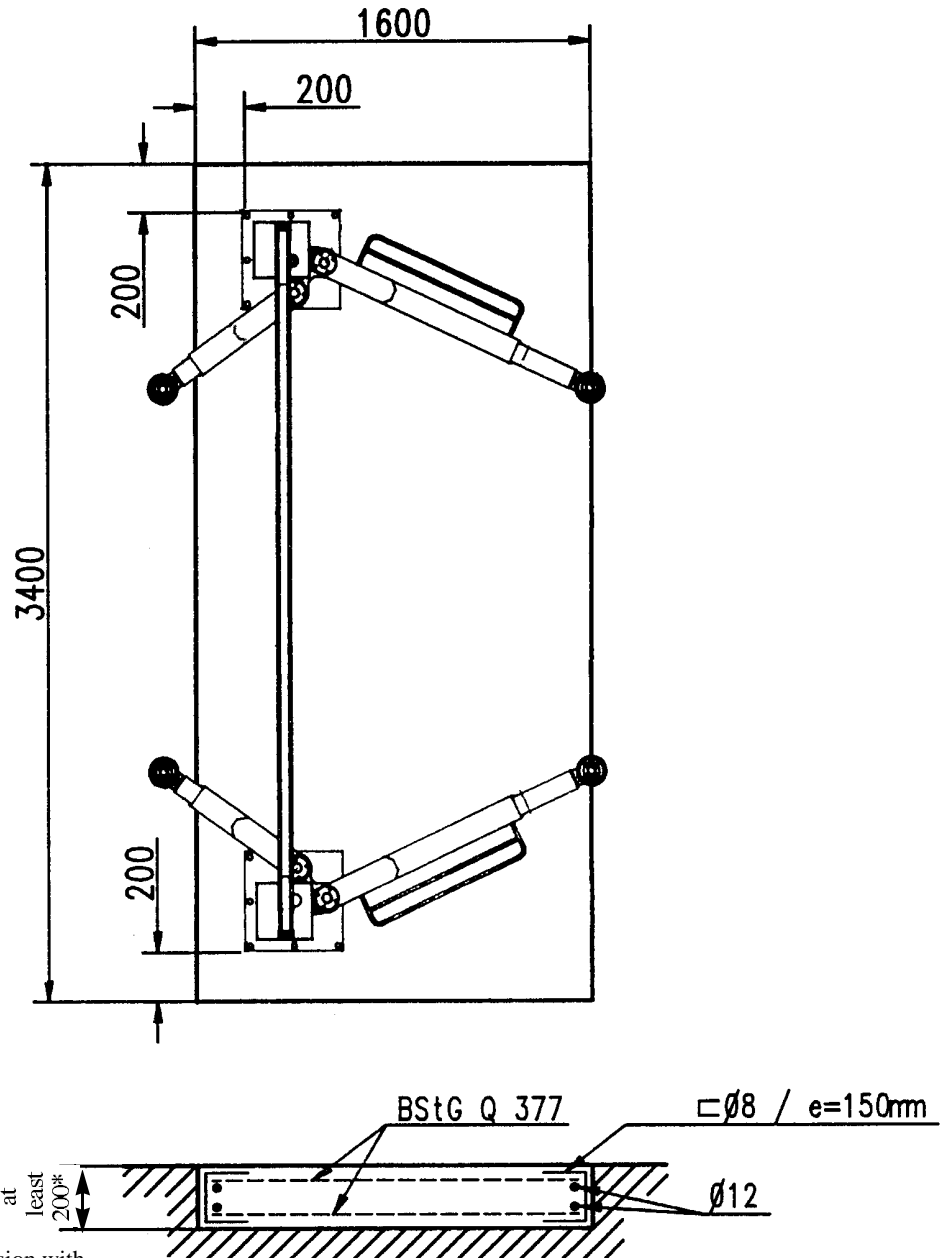

*) at least 150 mm for version with
base frame bow

reinforcement in both directions at the upper and lower side of the plate min 3,5 cm²/m
(for example structural steel Q 377)

revolving Ø8 / e = 150 mm

at the edges Ø 12

concrete quality min. B 25 (DIN 1045)

concrete covering for stiffening steel 2 cm

foundation base: frost-protected floor!

Block-foundationplan

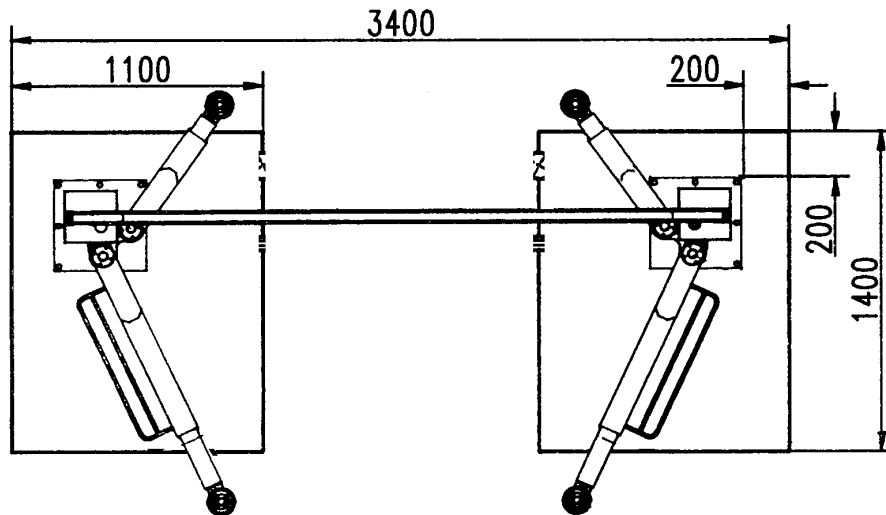

reinforcement:
constructional topside or
bottom crosswise

□ # ∅ 10/150
circulating at both sides

VE 3 ∅ 10

concrete covering for steel-insert

2 cm !

building material: concrete at least BN 250
steel: structural steel 42150
structural steel 50155

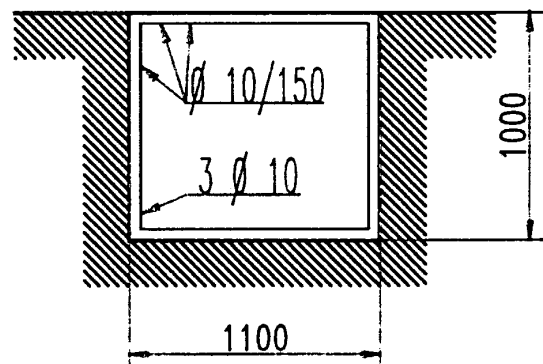

foundation base: frost-protected floor with foundation pressure p from at
least 15 N/qcm

Electrical diagram part 1

date: July 30th 1996
 Electricien: Braun
 drawing-n°.: 225SL E01-1

contact a-b is available only one time. It is a late-close switch, which works at position I (up) and at position II (down).

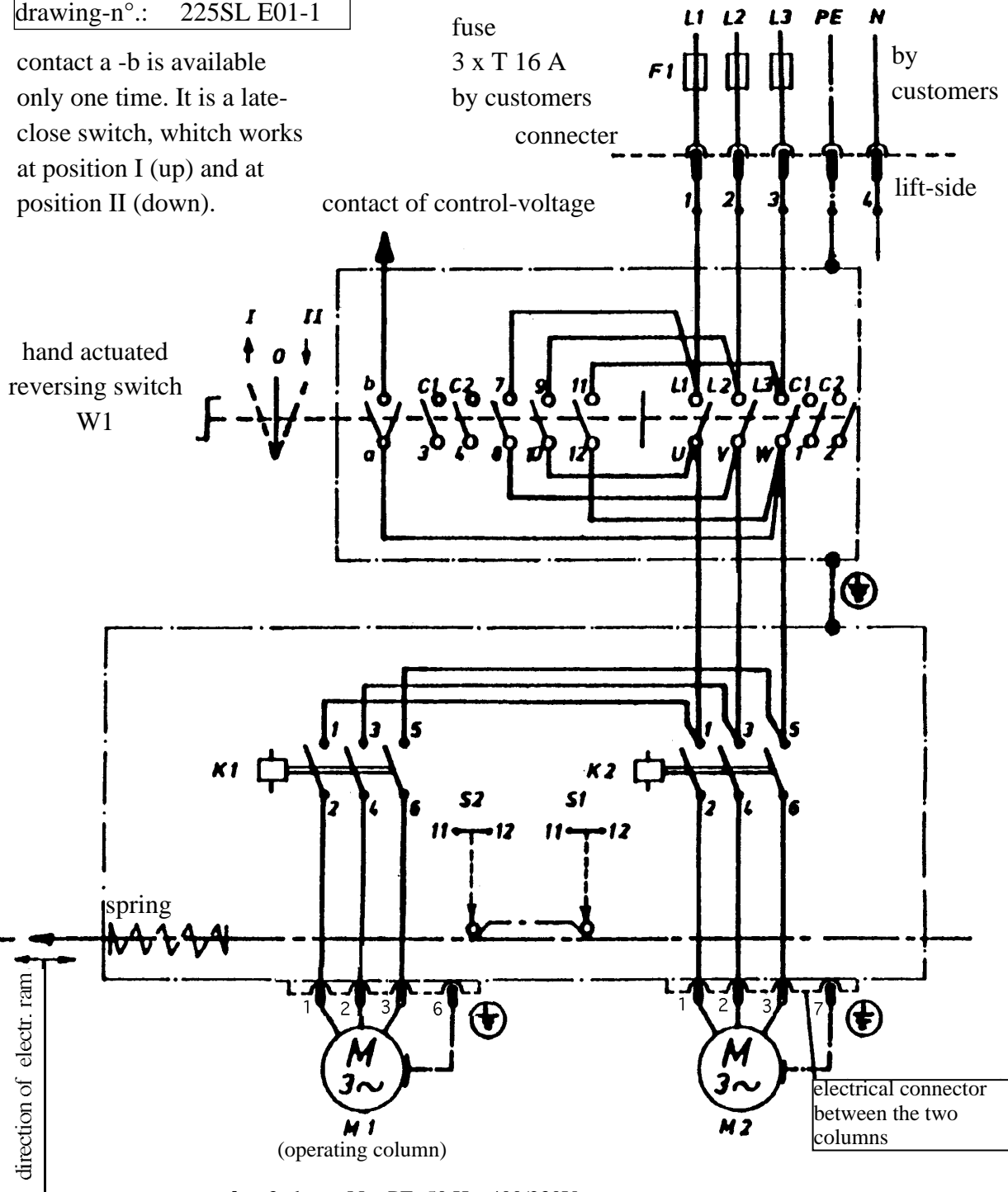

power supply: 3 phases/N + PE; 50 Hz 400/230V

choice of the protection measures: look of the local security regulations (BRD: VDE 0100)

by customers: electrical power line is to be secured with time-lag fuse 16 A; min wire-Ø: 1,5 mm²

Elektro-Schaltplan Teil2

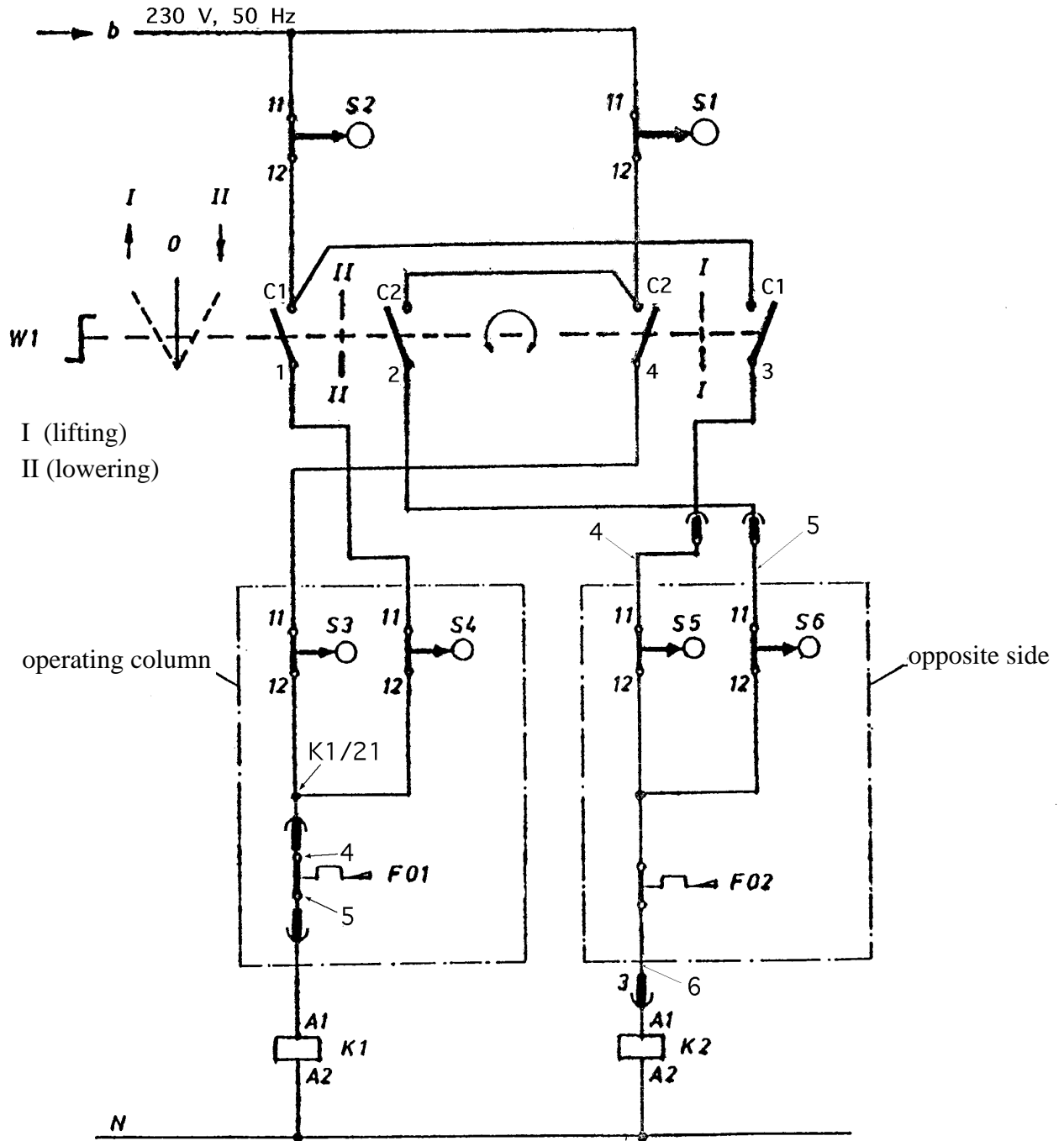

date:	July 30th 1996
Electricien:	Braun
drawing-n°:	225SL E03-1

Electrical parts list

- F01: thermofuse in motor
F02: thermofuse in motor
K1: motor contactor
K2: motor contactor
M1: motor 400 V, 1350 U/min, 2,0 kW; operating column
M2: motor 400 V, 1350 U/min, 2,0 kW; opposite column
S1: switch group at tappet (upper side)
S2: switch group at tappet (lower side)
S3: top limit switch; operating column
S4: bottom limit switch; operating column
S5: top limit switch; opposite column
S6: bottom limit switch; opposite column
W1: reversing switch

4. Safety regulations

Using automotive lifts for working the Regulations of Accident Prevention (VBG1: General Regulations, VBG14: Automotive lifts) must be observed.

Especially the following regulations are very important

- The laden weight of the lifted vehicle mustn't be more than 2500 kg for automotive lift 2.25 SL, the lifting capacity of one carrying arm mustn't be more than 750 kg for 2.25 SL. It is not allowed to load only one of the carrying arms.
- During working with the lift the operating instructions must be followed
- Only trained personnel over the age of 18 years old are to operate this lift
- During lifting or lowering the vehicle it must be observed from the operator
- It's not allowed to stay under the lifted or lowered vehicle (except for the operator)
- It's not allowed to transport passengers on the lift or in the vehicle
- It's not allowed to climb onto the lift during lifting or lowering or onto a lifted vehicle
- The Automotive Lift must be checked from an expert after changes in construction or after repairing carrying pads
- It's not allowed to start with operations at the lift before the main switch is switched off
- Switching on or switching off the lift pay attention that the lifting and lowering movement are steady
- It's not allowed to install the standard-automotive lift in hazardous location

5. Operating instructions



The Safety Regulations must be observed during working with the automotive lift. Read the safety regulations in chapter 4 carefully before working with the lift!



Indication: lift can be adjusted repeatedly during operating

The operating elements are shown in **picture 2**.

Lifting the vehicle with the automotive lift

- Drive vehicle in the lift, longitudinal direction and transverse direction in centre
- Determine adjustable pads at the points which are provided from the vehicle manufacturer (**pic. 1**)
- Control the dangerous places of the lift and be sure that there are no objects or people in the immediate area of the lift or on the lift
- lift the vehicle free and check the sit of the pads

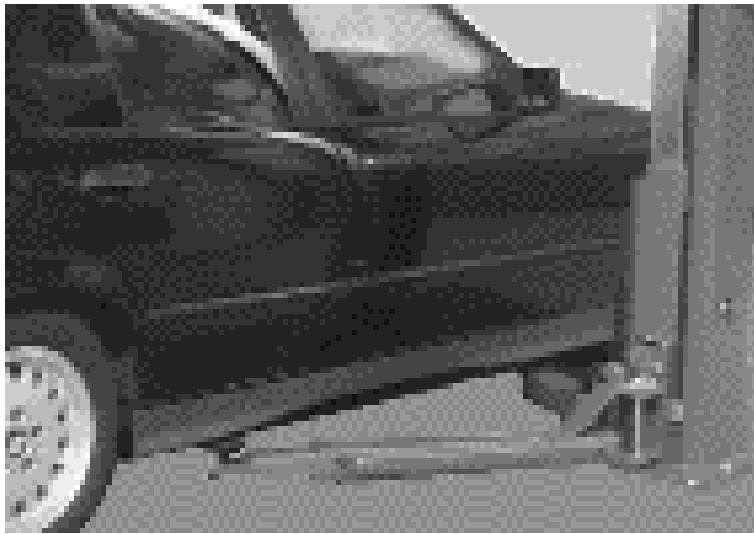

pic. 1: Determine adjustable pads at the points which are provided from the vehicle manufacturer

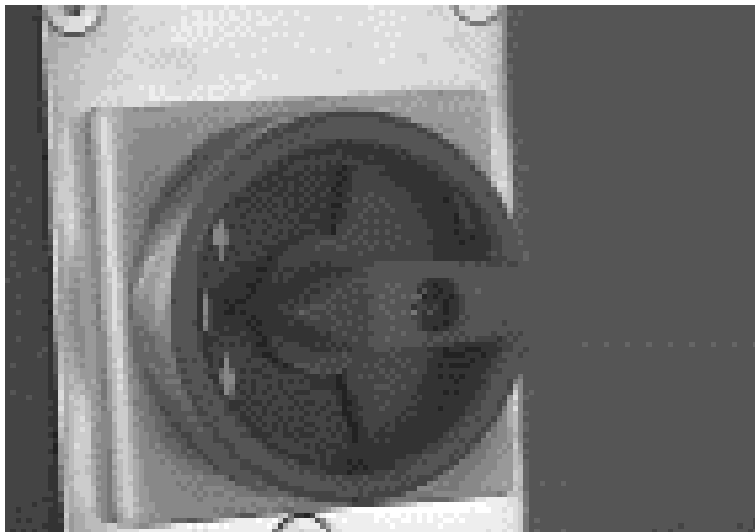

pic. 2: reversing switch

- lift the vehicle until the wheels are free; turn reversing switch to „lifting“-position (upside)
- When the wheels are free: interrupt lifting and check the sit of the pads again



The sit of the pads under the vehicle is very important. If the position of the pads isn't all right the vehicle might fall down!

- Lift the vehicle on the height for working; turn reversing switch to „lifting“-position (upside)

Lowering the vehicle with the automotive lift

- Control the dangerous places of the lift and be sure that there are no objects or people in the immediate area of the lift or on the lift
- Lower the vehicle at the height for working or until the carrying arms reach the lowest point; switch to „lowering“-position (downside)
- Drive vehicle out of the lift, when the lift is in lowest position

6. Troubleshooting

If the lift does not work properly, the reason for this might be quite simple. Please check the lift for the potential reasons mentioned on the following pages. If the cause of trouble cannot be found, please call the technical service.



Repairs at the lift's security devices as well as repairs and examinations of the electrical fittings may only be performed by specialists!

Problem: Motor does not start

- Potential causes of trouble:**
- Main switch is not engaged
 - Feed line is cut
 - fuse is defect
 - Motor is overheated: let it cool down for app. 10 min.
 - Lift is driven onto an obstacle

Problem: Motor starts, lift is not lifting!

- Potential causes of trouble:**
- broken nut: refer to function of switching off
 - height limit switch is engaged
 - torn control rope

Problem: Lift cannot be lowered!

- Potential causes of trouble:**
- bottom limit switch is engaged
 - broken nut: refer to function of switching off
 - torn control rope

Emergency lowering in case of power failure

In case of power failure the lift can't be lowered with the motor. In this case there is the possibility to lower the lift manually. For this the lift must be turned down to lowest position at the nut on the top end of the spindle. When the lift is at lowest position the vehicle can be removed from the lift



The emergency lowering must only be performed by persons instructed to use the lift. Please refer to the regulation "Lowering".

Emergency lowering

- Switch off and lock main switch
- Lower the lift-carriage at the big V-belt pulley. For this take care, that the height difference between right and left carriage is not more than 10 mm.

Function of limit switches

If the lifting carriage or the extension arm has driven because of inattentiveness onto an obstacle, the lift stops automatically.

To avoid blocking of the lifting carriage (operating side) in drive-on direction a fuse is built in motor, which interrupt the driving current of the motor in case of overstressing. A further operating of the lift is possible only after a few minutes (cool down of motor).

Actuation of safety switching

The lift is equipped with a safety switching, which controls the wear of the main nut and the wear of the chain. If the lifting nut breaks a safety nut which is conducted loose in the spindle carries the load. The lift can only be lowered in lowest position and can't be lifted any more. Simultaneously (in case of broken lifting nut) the tappet is pulled from the control rope until the position switches are pressed and both motors shut down.

The lift cannot be operated from the operating elements any more.



If the safety switching is actuated the service must be called in any case, because the lift is defect!

A control of the lift's current supply is necessary, means looking if the fuses are all right and the switches are engaged.



In case of any obstruction and in case of repairs at the lift the main switch must be switched off and be safeguarded against reengaging



Only experts or competents are allowed to open the switch box.

Control of synchronization (mechanically)

To guarantee synchronization of the two lifting carriages, the lifting carriages are connected via control rope with a tappet. In case one lifting carriage is max. 20 mm earlier at a definite height, the tappet is pulled. The tappet presses one of the two position switches located at the tappet and this carriage which has been earlier at the definite height stops until both carriages are at the same height again.

In case of torn control rope a pressure spring presses the tappet down until both switches are pressed and both motors are switched off.

7. Maintenance

A regular service has to be performed every three months by the lift's operator according to the following schedule. If the lift is in continuous operation or dirty environment, the maintenance rate has to be increased.

During daily operation the lift has to be watched carefully for its correct function. In case of any malfunction or leakage the technical service has to be informed.

pic. 3: Maintenance schedule for 2-columns-lifts

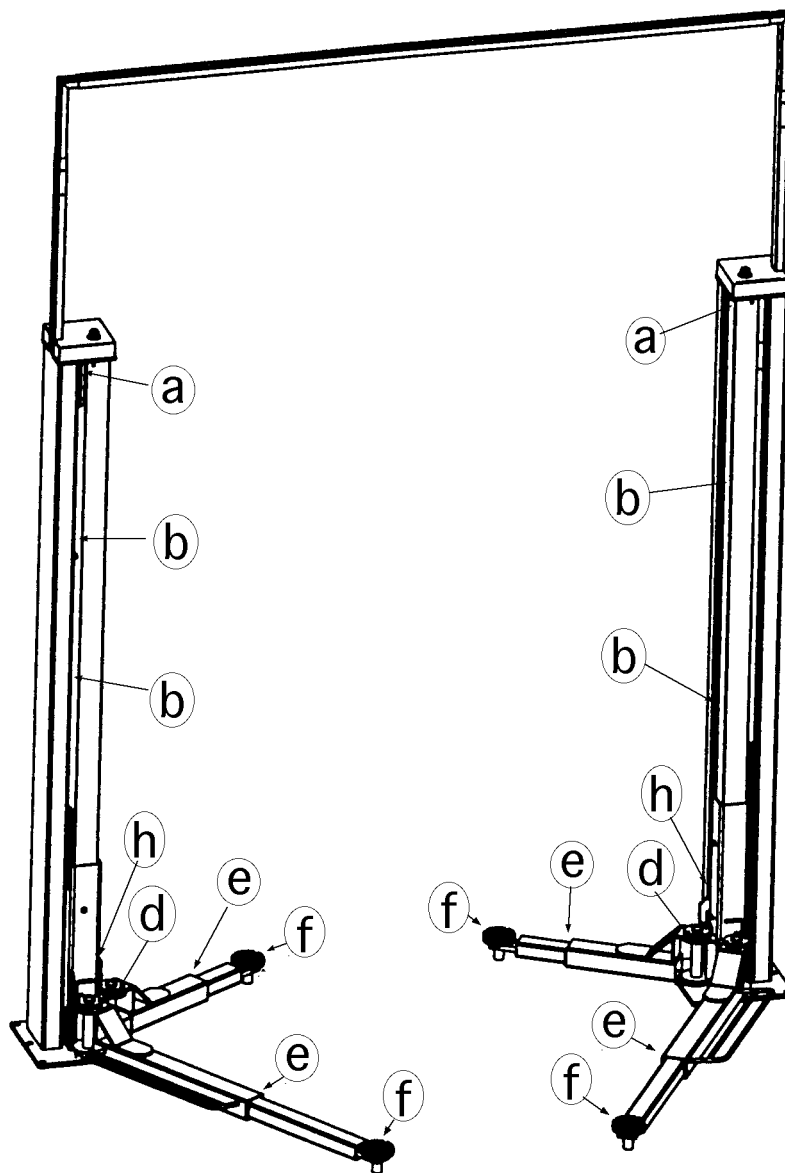

Maintenance schedule for the lift (see picture 3)

- d, e, f** Grease the pull-outs of the carrying arms, bolts of pads and slide ways of carriage slide rollers
- b** Lubricate spindle one time a month a little bit. The Saw-chain-bonding oil T 320 (OEST) is recommended.



Take care, that biological decomposable saw-chain-bonding oil is not used. In this case the lift might be damaged!

- f** Check rubber flooring of the pads and change them if they are worn
- h** Grease sequence nut one time a month with multipurpose fat. Use boring at lifting carriage
- a** Grease spindle bearing annually with multipurpose fat
- g** Grease control ropes and pulleys monthly with multipurpose fat a little bit and lubricate them with oil-spray (non-resin) a little bit.

When the lift is installed the lubricating felt between nut-support and lifting nut is to oil very well. Use a saw-chain oil which can also be used when the spindle is rotating and which doesn't be thrown away. The oil receiver constituted from the carrying plate, must be filled with oil completely. The lift must be driven in lowest and in top position. Afterwards the lift must be checked with load to look after smooth running of the lift. The lubrication of the nut is carried out with oil can through column and covering sheet. This lubrication must be repeated every 2-4 weeks depending on time the lift is used. It is referred to the emergency lubrication characteristic of the NYLATRON-lifting nut. However a regular lubrication described in the previous section guarantees a careless operating of the lift.

Adjusting of the polyflex-belt

If the driving-belt is replaced the belt-tension must be probably adjusted again. For this the coverings of the columns must be removed (**pic. 4**). Afterwards the belt-tension is adjusted again at the „tension-element“ (**pic. 5**): Loosen the 3 fixing screws of the motor (**pic. 6 n° 1**) for one turn. Now the belt can be tensioned or be loosen up (**pic. 6 n° 2**). With the help of an accessory-tool (**pic. 7**), which can be sent from *Nußbaum Hebetchnik GmbH & Co.KG*, and a spring balance (**pic. 8**) the polyflex-belt is adjusted to its right belt-deflection (max. 1,5 mm).

The necessary force for deflection of the belt (belt-deflection: 1,5 mm) is 65 N!

For this the accessory-tool must be touched the belt as shown in **pic. 9**. Afterwards the fixing screws of the motor must be fastened again.

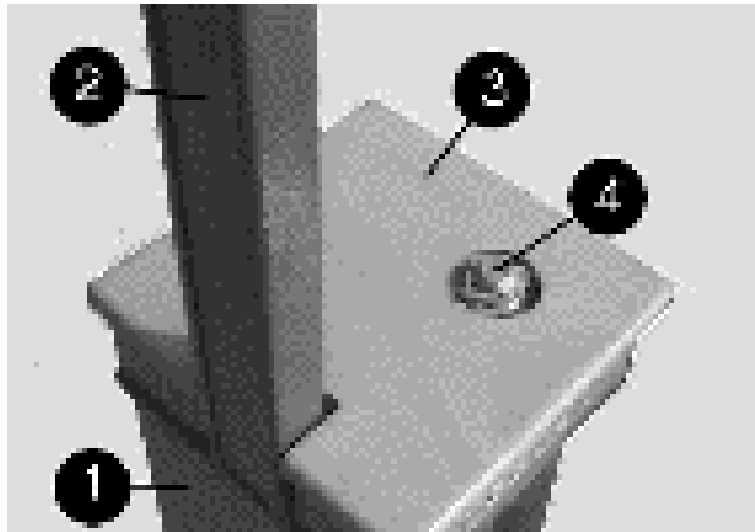

pic. 4: covering of the column

1: column; 2: ascending pipe; 3: covering of the column; 4: spindle

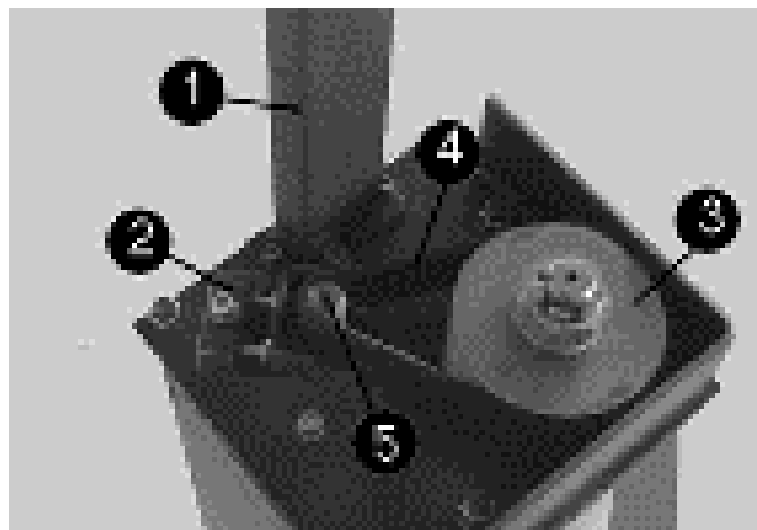

pic. 5: Position of the driving-belt

1: ascending pipe; 2: tension-element for adjusting the belt-tension; 3: pulley;
4: polyflex-belt (driving-belt); 5: motor shaft

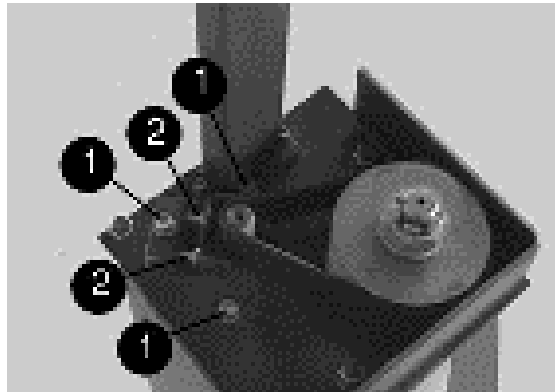

pic. 6: adjusting of the belt-tension

1: fixing screws of motor

2: adjusting screws for belt-tension

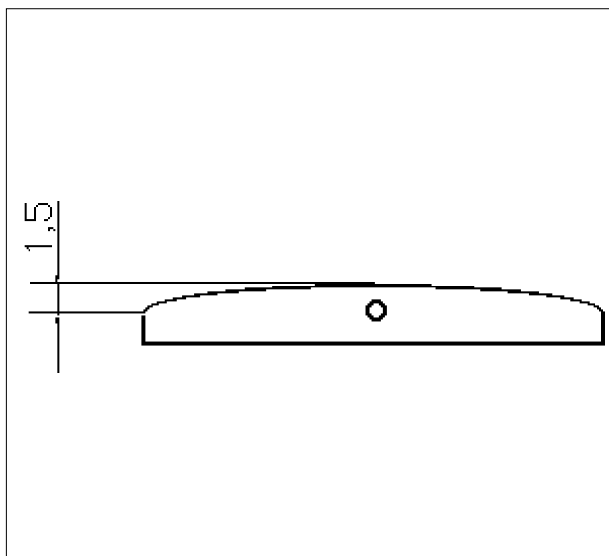

pic. 7: accessory-tool for adjusting of the maximum belt-deflection of 1,5 mm

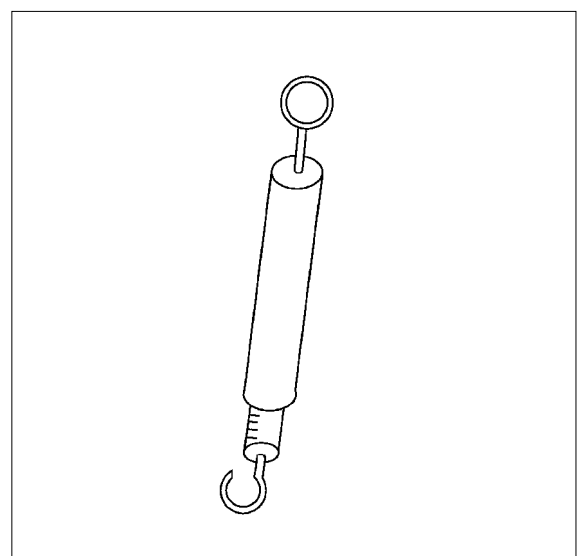

pic. 8: spring balance for adjusting of the belt-tension (65 N)

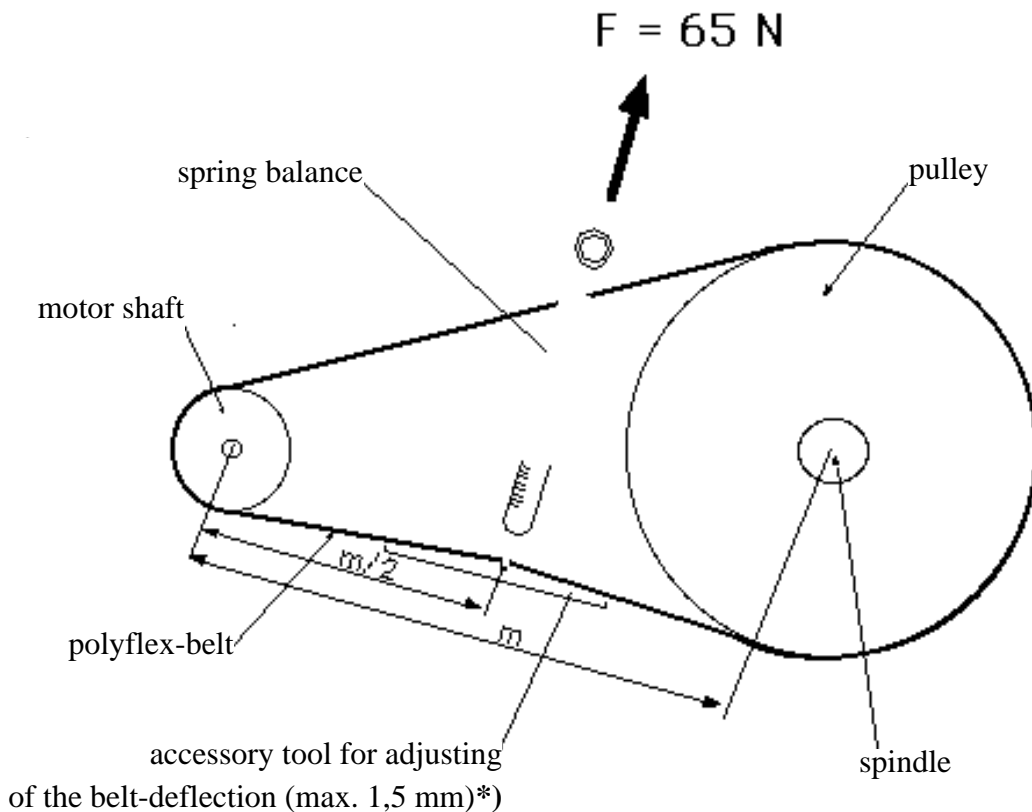



*) belt must touch the accessory-tool

8. Security check

The security check is necessary to guarantee the safety of the lift during use. It has to be performed in the following cases:

1. Before the initial operation, after the first installation.
Use the form "First security check".
2. In regular intervals after the initial operation, at least annually.
Use the form "Regular security check".
3. Every time the construction of that particular lift has been changed.
Use the form "Extraordinary security check".

 ***The first and regular security checks must be performed by a competent. It is recommended to service the lift at this occasion.***

 ***After the construction of the lift has been changed (changing the lifting height or capacity for example) and after serious maintenance works (welding on carrying parts) an extraordinary security check must be performed by an expert.***

This manual contains form with a schedule for the security checks. Please use the adequate form for the security checks. The form should remain in this manual after they

have been filled out. In the following there is a short description about special safety devices.

- carrying nut (optical wearing measure). To check the carrying nut take off covering from the spindle. There is a pin built in the carrying plate (see **pic. 10**). This pin must be even with the top edge of the carrying plate (lifting carriage

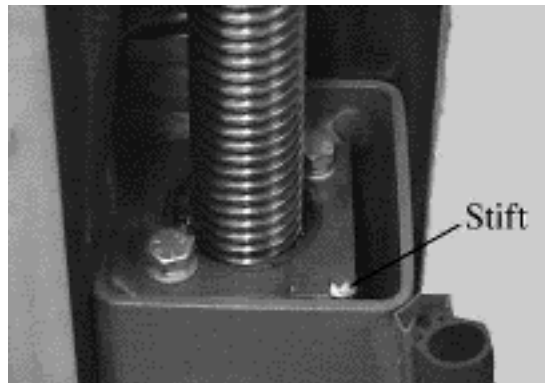

pic. 10 : lifting carriage with pin (= Stift)

upper side; built-in state see **pic. 11**). If the pin looks 2 mm out of the top edge at the annually check (see **pic. 10** changing state) the carrying nut and the sequence nut must be changed.

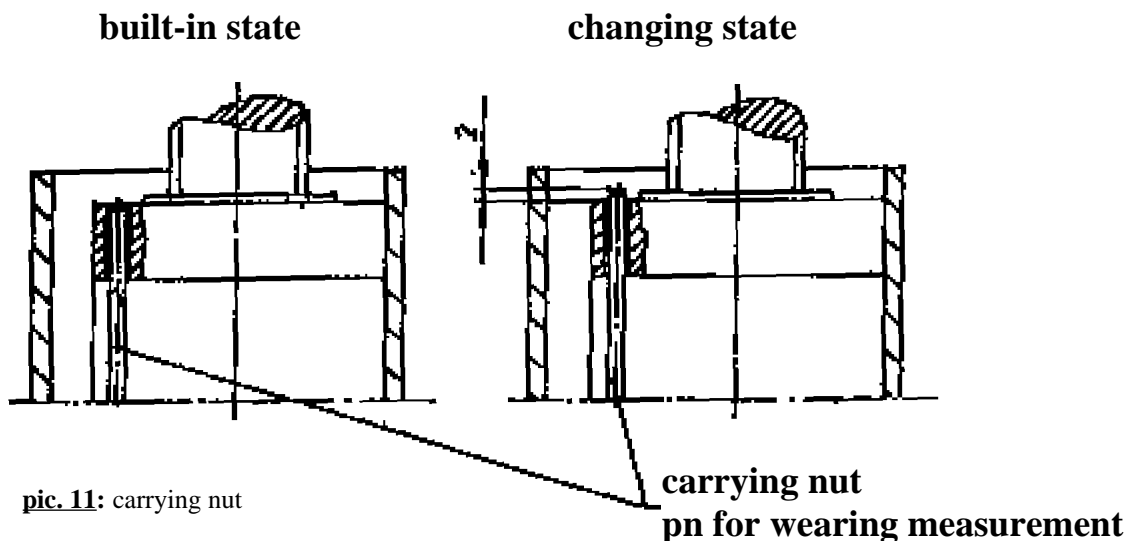

pic. 11: carrying nut

- Check height limit switch and bottom limit switch. They have to be all right otherwise the must be changed.
Check of limit switches: One man must be lift or lower the lift. A second man actuates the height limit or the bottom limit switch. If the switches are all right the lift stops after every actuation.
- stability: The nuts of the dowels must be tightened with a dynametric key (M = 80 Nm)

- Installation in wash-halls: pay attention to safety of the electrical equipment against water

9. Installation and Initiation

Installation of the lift

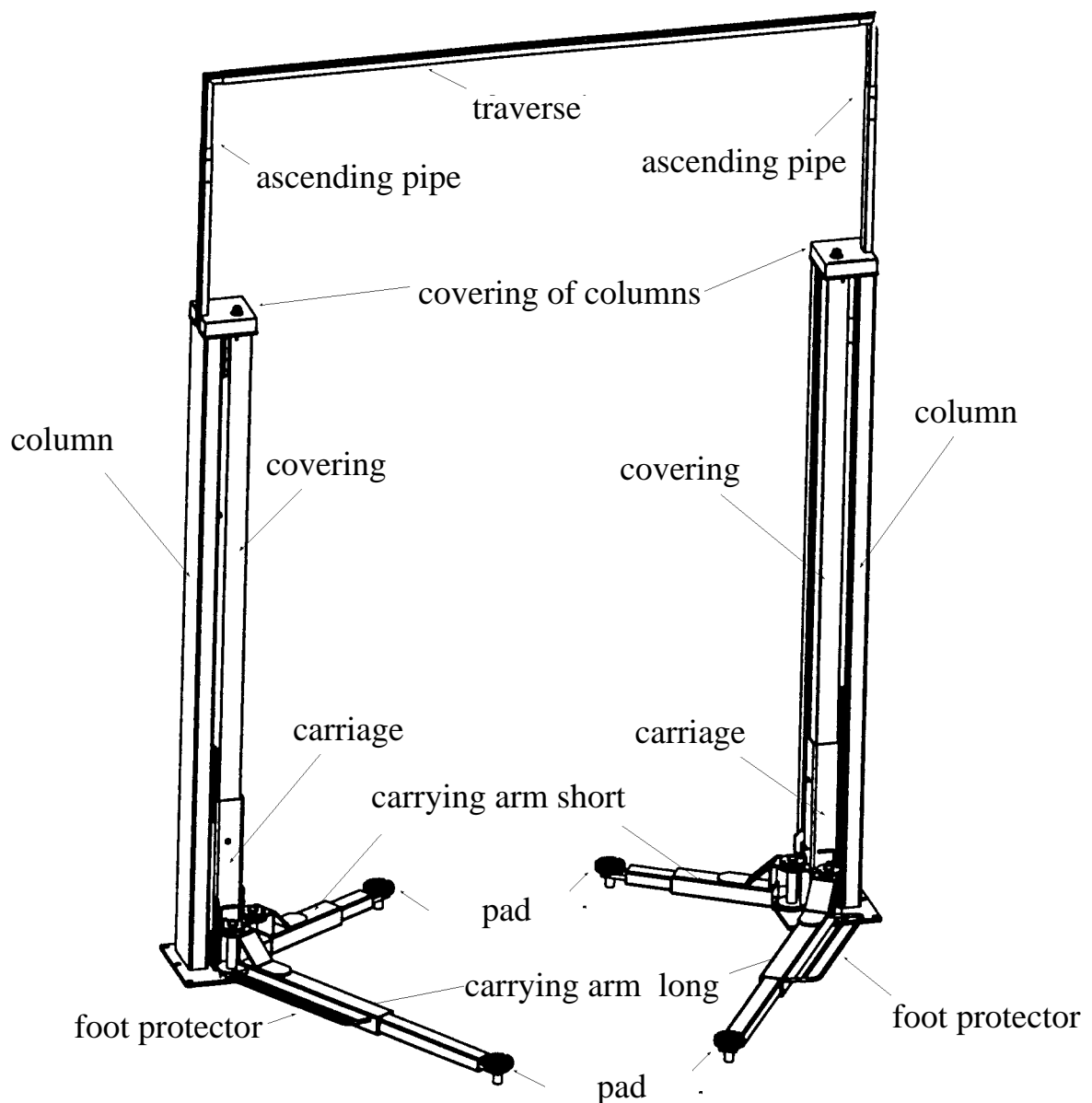

pic. 12: Installation assembly

Regulations for the installation

- The installation of the lift is performed by trained technicians of the manufacturer or its distribution partner. If the operator can provide trained mechanics, he can install the lift by himself. The installation has to be done according to this regulation.
- The standard lift must not be installed in hazardous locations or washing areas.
- Before installation a sufficient foundation must be proved or constructed.
- An even installation place has to be provided. The foundations must be based in a frost resistance depth, both outside and indoors, where you must reckon with frost
- An electric supply 3~/N + PE, 400 V/230 V, 50 Hz has to be provided. The supply line must be protected with T 16 A (VDE 0100). The min. diameter amounts to 1,5 mm².
- The cable entry in the column is located in operating column (motor box) topside (standard version). Another possibility is the location of cable entry in a boring at the base plate. However the cable has to be secured with a cable bushing.
- Installation in wash-halls: pay attention to safety of the electrical equipment against water

Erection and doweling of the lift

It is necessary to dowel the lift against slipping. For this you need a concrete floor with a thickness of at least 260 mm and a quality of at least B 25. In case of doubt a test boring has to be performed and a dowel is to set in. Afterwards the dowel must be tightened with a torque of about 80 Nm. If there are defectives (cracks or hairline cracks) in the zone of influence (Ø 200 mm), the foundation cannot be used to install the lift on it. A foundation must be constructed in accordance with the form "foundation plan".

It must be paid attention of an even installation place of the lift because of a straight contact between lift and concrete floor.

- Put and line up columns in accordance with data sheet to the installation place. Screw cable suspension bridge on columns
- Check position of the lift
- Bore holes to fix the dowels through the borings of the base plates (**pic. 13**). Clean holes with pressure air. Put in safety dowels with washers in borings. The manufacturer demands LIEBIG safety dowels type B 20. Before doweling check concrete floor with quality B 25 if the concrete floor goes to the top edge of the floor. In this case the dowels have to be chosen according to **picture 20**. If the ground is covered with floor tiles, the dowels have to be chosen according to **picture 21**.
- Check the line-up of the columns and look if they are vertical. If they aren't vertical correct with suitable bases.
- Tighten the dowels with a dynamometric key (M = 80 Nm)

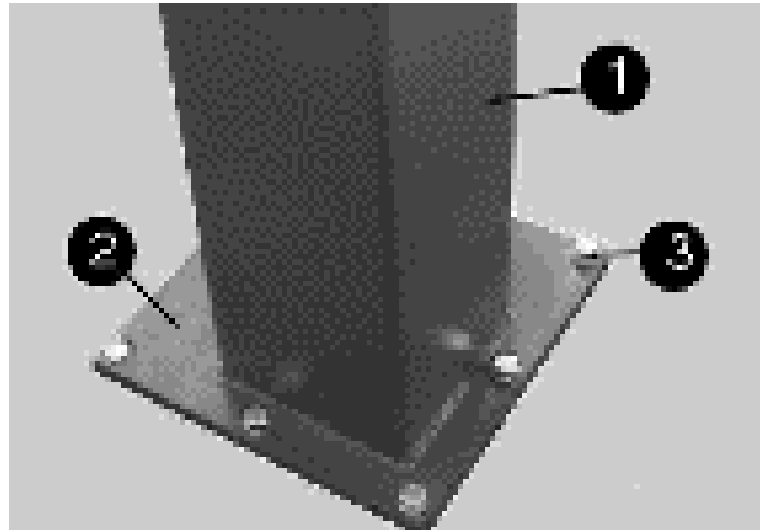

pic. 13: doweling

1: column; 2: base plate; 3: safety-dowel

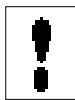

Each dowel must be tightened with a torque of 80 Nm. The normal function of the lift cannot be guaranteed

- If the possible torque is 80 Nm and if the arched U-washer lies flat on the checking plate after tightening of the dowelnut, you have got a safety dowel connection
- Unscrew coverings at the frontside and backside of the operating column.
- Connect power supply. The cable entry is at the top of the motor-box (operating column) for standard version. The coverings at frontside are only fixed at the top and can be pulled out after unscrewing. But for this the lifting carriages must be lowered to lowest position (see **pic. 14**, **pic. 15** and **pic. 16**)

Electromounting and Supplypoint

- There are two cables in the operating column: with 7 wires and with 5 wires
- The 5-wires-cable is for connection with power supply (wire 4 is neutral-wire!). The 7-wires-cable is pulled through the traverse to opposite side (the ascending pipe has got an opening with screwing. Through this opening the electrical cable can be pulled.
- Afterwards there must be wired at the top of the opposite column

pic. 14: Put in coverings

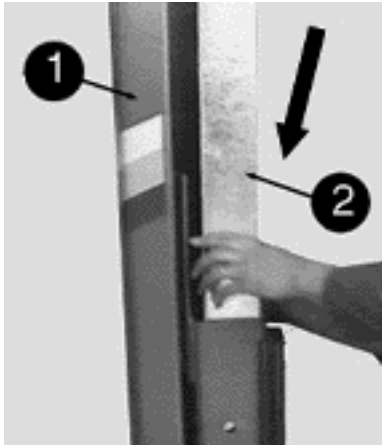

1. column
2. covering of column

pic. 15: covering lower side

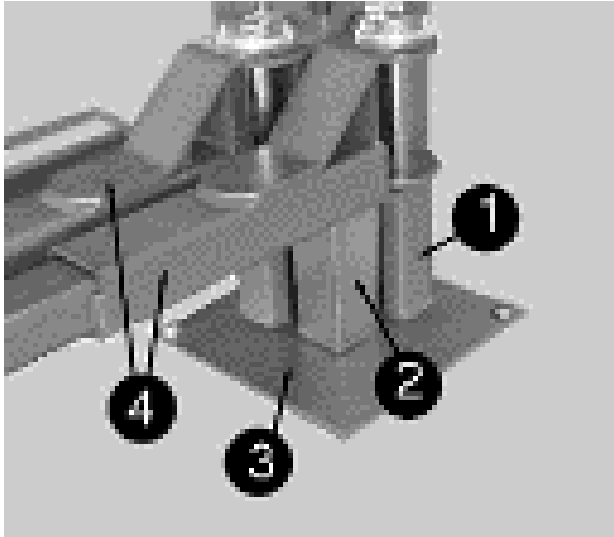

1. column
2. covering of column
3. base plate
4. carrying arms

pic. 16: covering top side

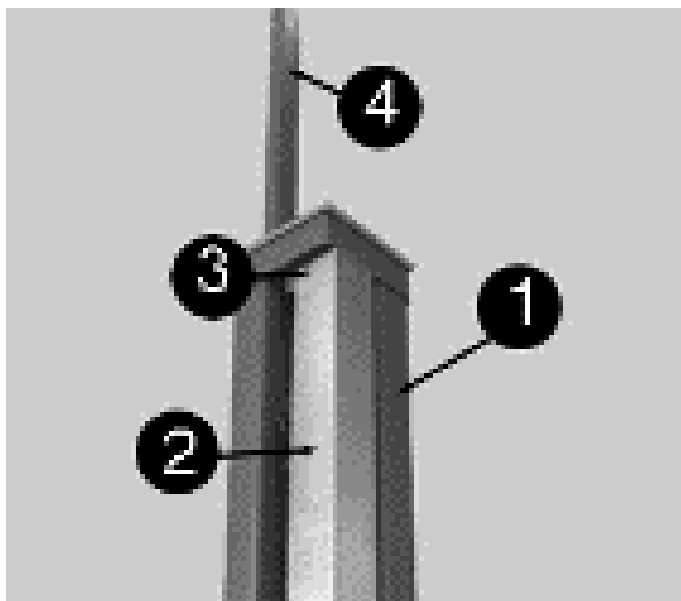

1. column
2. covering
3. screws for covering
4. ascending pipe for electrical wires and control rope

Installation of control rope

- Pull Bowden-pull-wire through ascending pipes and through traverse (**pic. 18**).
- Pull hang-up nipple, which is connected with the end of the control-rope, from column headplate to lower side of **operating column**. Put control-rope round the pulley, which is connected with the tappet (**pic. 17 and 19**). Hang-in control rope at carriage.

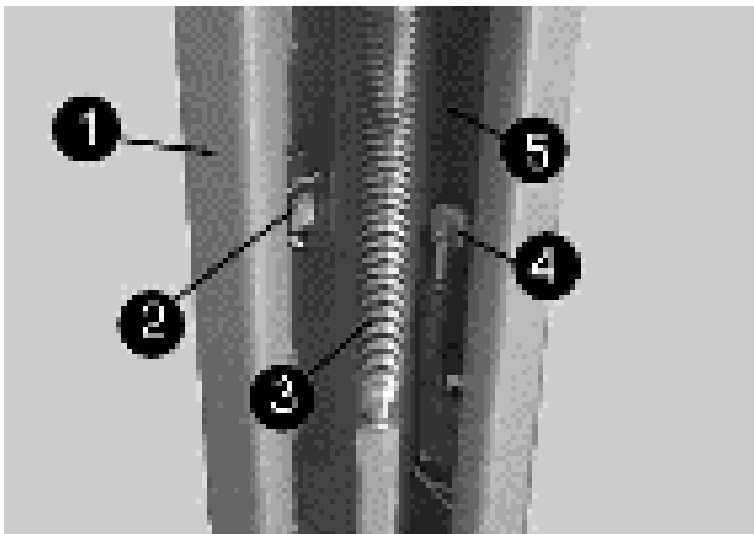

pic. 17: pulley with control rope

- 1: operating column
- 2: bottom limit switch
- 3: spindle
- 4: pulley
- 5: control rope

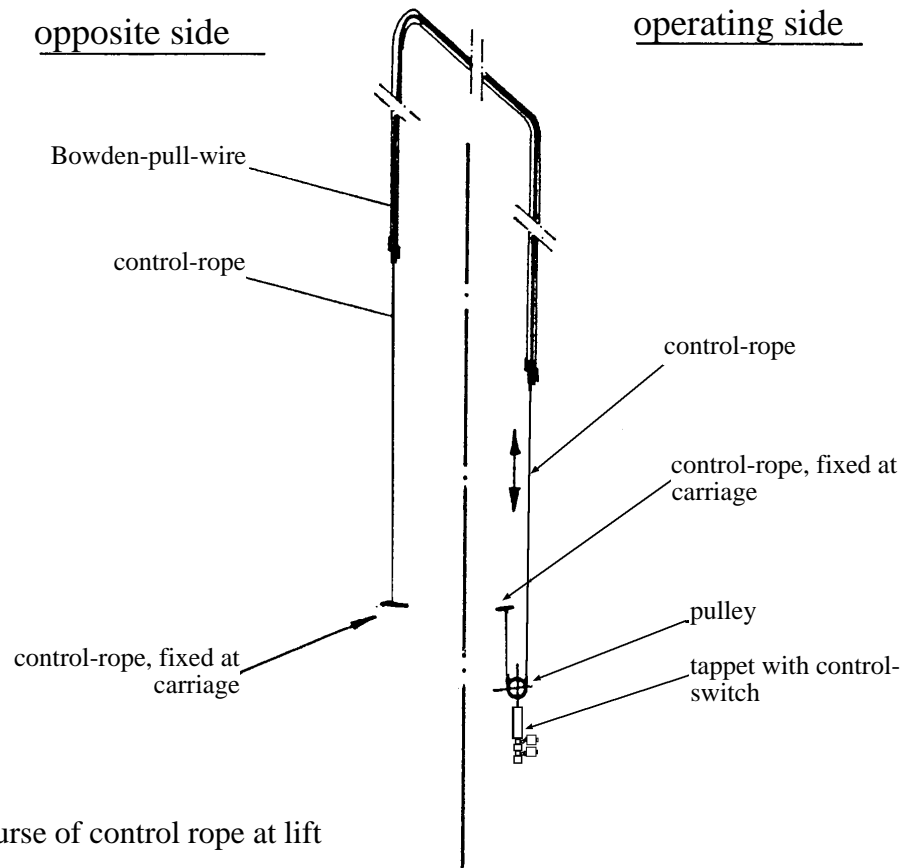

pic. 18: course of control rope at lift

Additional installation of control rope (since June 24th 1996)

For regulation of control rope an accessory adjusting screw is mounted at ascending pipe of opposite side. (pic. 19a)

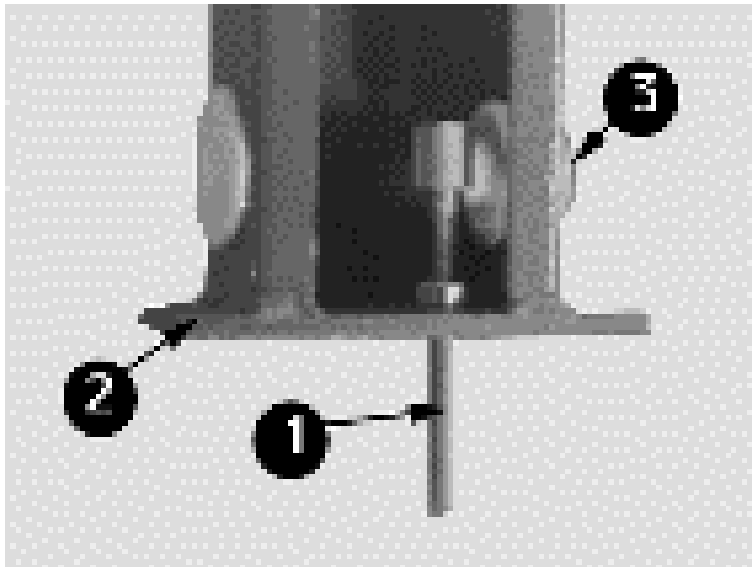

pic. 19a: Position of adjusting screw at ascending pipe of opposite side

- 1: adjusting screw
- 2: ascend. pipe oppos. s.
- 3: cable bushing for electrical power supply and for control cable

Put bowden shell of control rope in adjusting screw. Pull control rope through shell and through adjusting screw (pic. 19b).

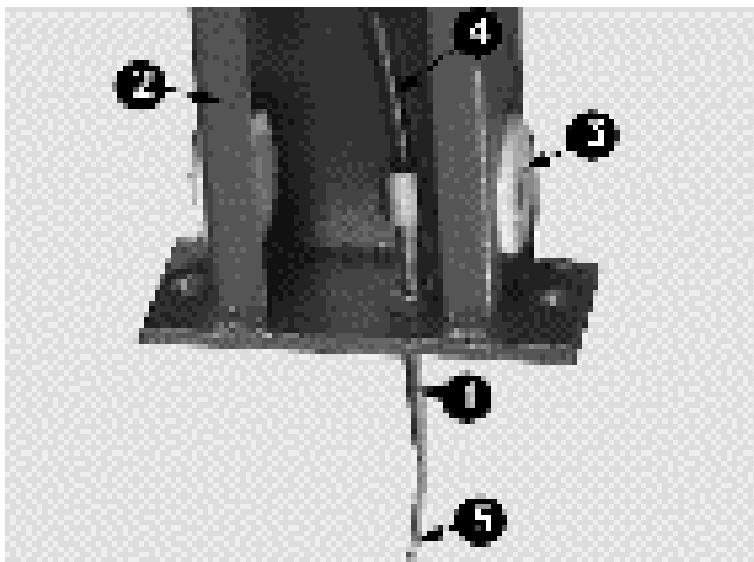

pic. 19b: adjusting screw with bowden cable

- 1: adjusting screw
- 2: ascend. pipe oppos. side
- 3: cable bushing for electrical power supply and for control cable
- 4: bowden shell
- 5: control rope

There is a difference between ascending pipe of opposite and operating side you can see at **pic. 19c**:

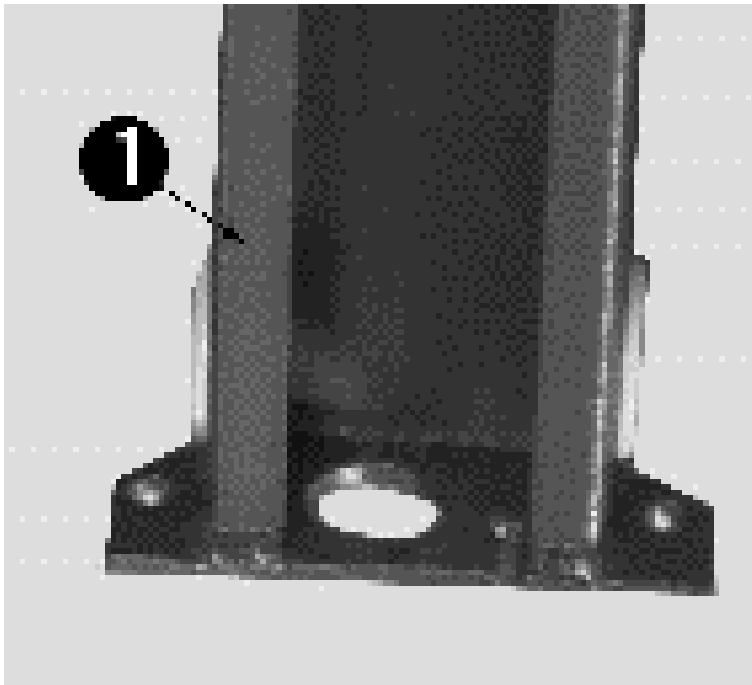

pic. 19c: ascending pipe of operating side

1: ascending pipe of operating side

The wooden bar for installation is positioned under the tappet (**pic. 19d**) to avoid activating of the control switches during installation. After mounting of control rope, the wooden bar must be removed.

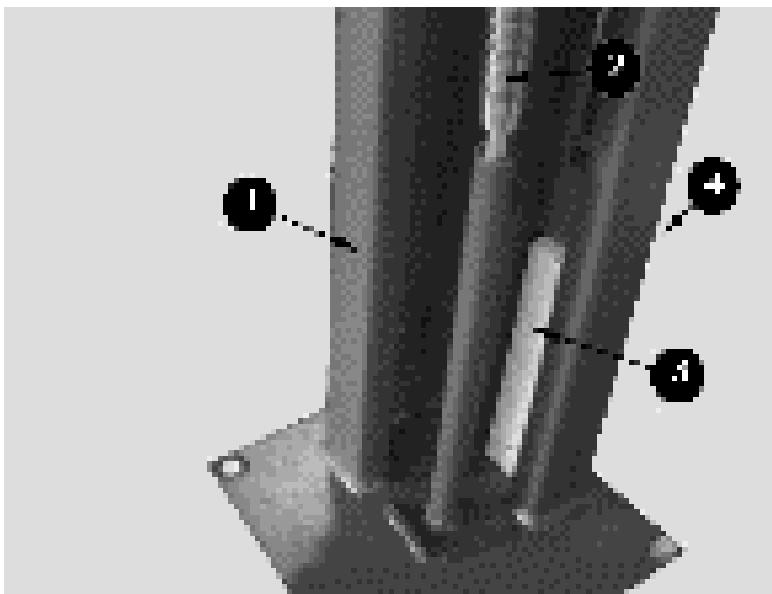

pic. 19d: wooden bar at tappet

1: operating column
2: spindle
3: wooden bar
4: control switch

Installation of carrying arms

- Install carrying arms and bolts top and bottom with enclosed circlips (**pic. 20**).

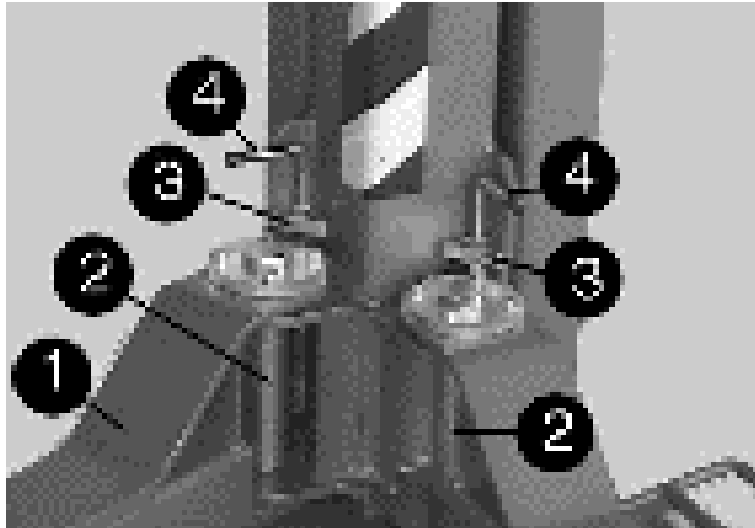

pic. 20: Installation of the carrying arms

- 1: carrying arm
- 2: bolt of carr. arm
- 3: fixing device
- 4: pull-rod



The carrying bolts must be secured at both sides , otherwise a correct connection between lift carriage and carrying arm cannot be guaranteed.

- Lift and lower the lift with vehicle several times, tighten dowels a second time (M = 80 Nm)

Initiation



Before the initiation a security check must be performed. Therefore use form: First security check.

If the lift is installed by a competent, he will perform this security check. If the operator installs the lift by himself, he has to instruct a competent to perform the security check.

The competent confirms the faultless function of the lift in the installation record and the form for the security check and allows the lift to be used.



Please send the filled installation record to the manufacturer after installation.

Changing of the installation place

If the place of installation shall be changed, the new place has to be prepared according to the regulations of the first installation. The changing should be performed in accordance with the following points:

- lift carriage to medium height
- Take away current supply from lift
- Dismount carrying arms (take off circlips from carrying arm bolts, take off carrying

arm bolts and dismount carrying arms)

- Take off load chain at the chain connection
- Loosen screws from base frame and take off columns
- Install lift in accordance with chapter "Installation and Initiation" of the lift.



Use new dowels, The used dowels cannot be used any more.



A security check must be performed before reinitiation by a competent. Use form "Regular security check".

picture 20: choice of the dowel lengths 2.25 SL without floor pavement or tile surface

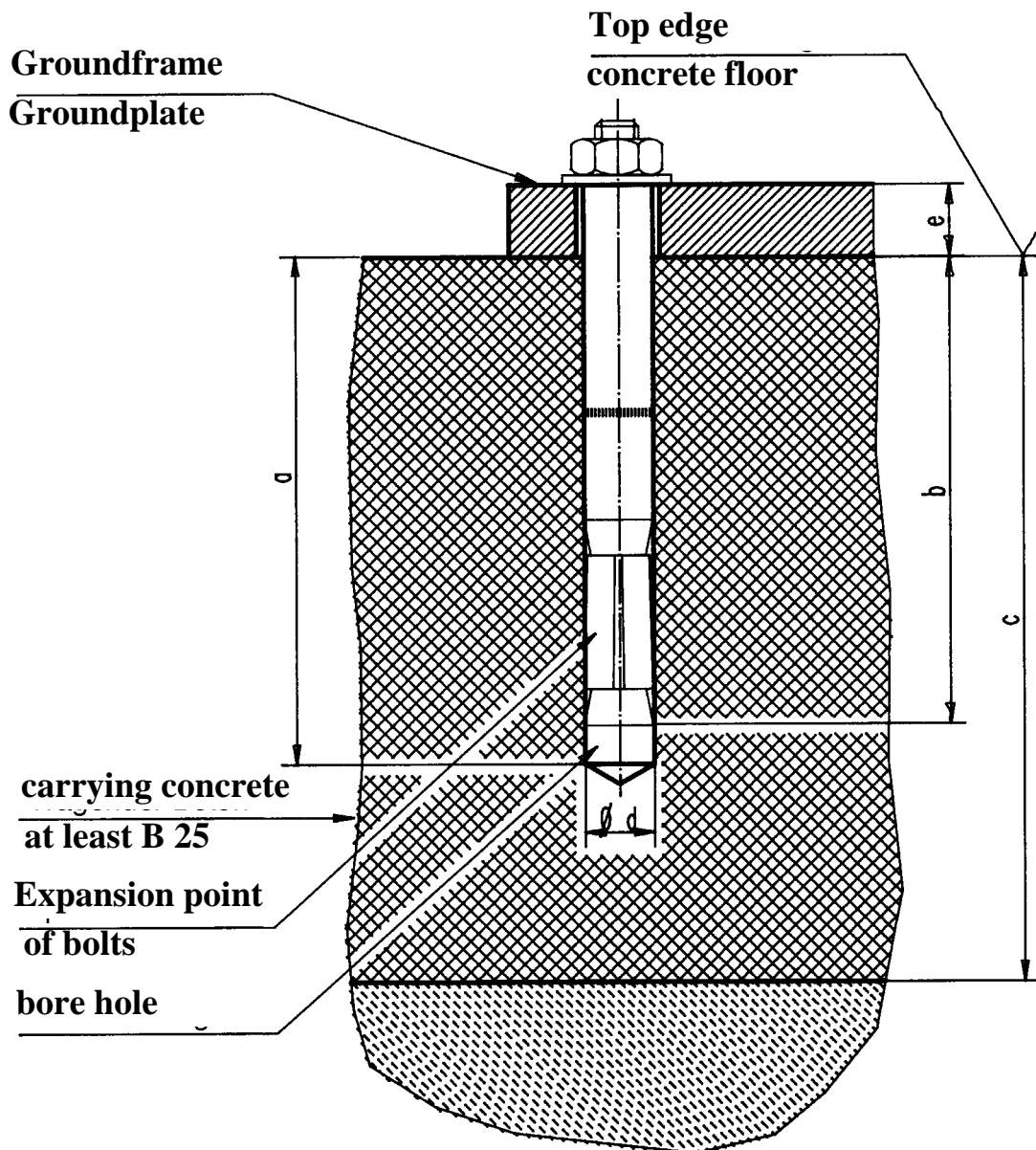
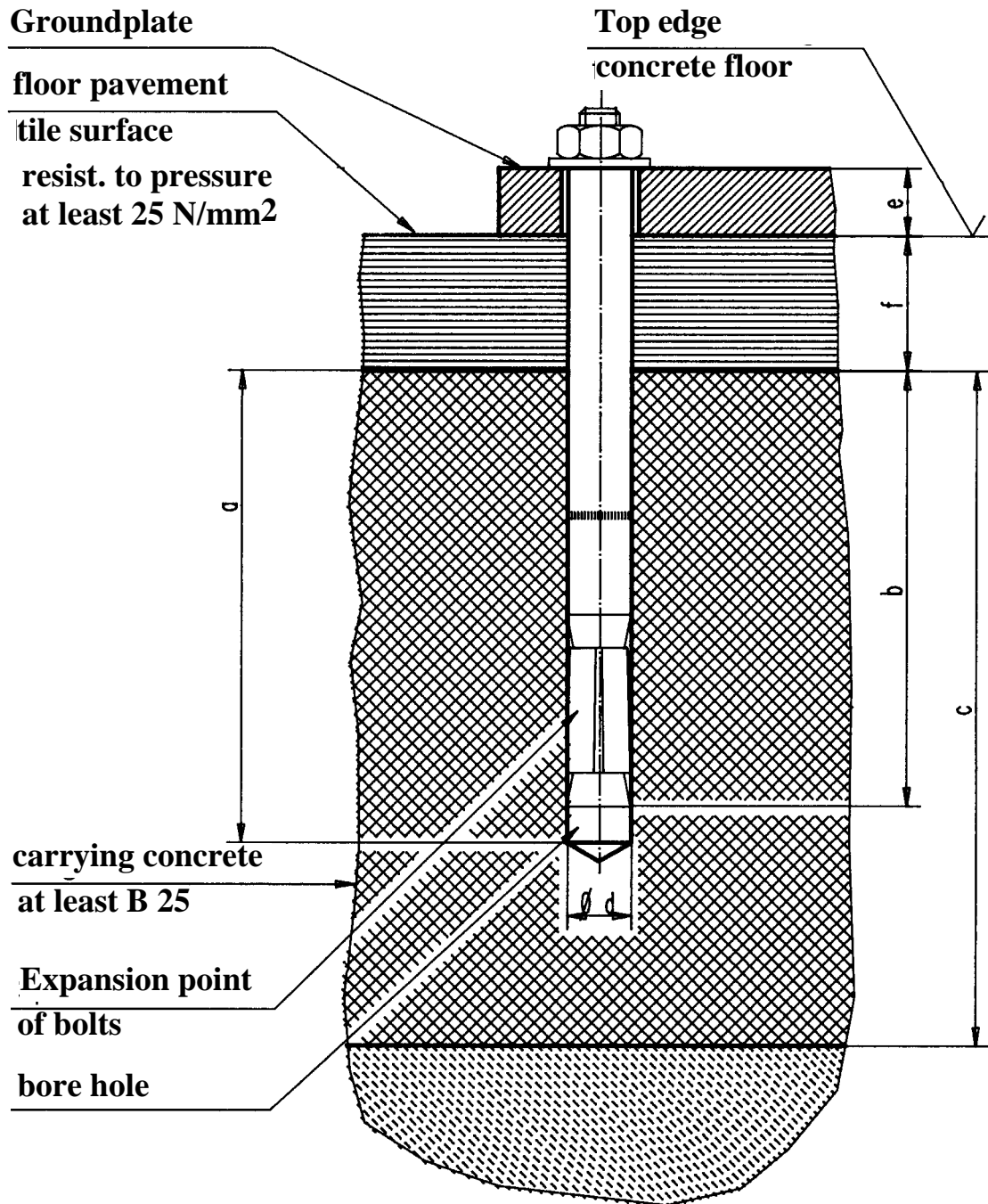

table to picture 20:
dowel type

Liebig B20; UPAT UMV 100 (or UMV 80 for version with base frame bow) or equal dowels of other manufacturers (with authorization)

Drilling depth	a	according to dowel manufacturer
min. anchorage depth	b	100 mm (or 80 mm for version with base frame bow)
thickness of concrete	c	at least 200 mm (or at least 150 mm for vers. w. base fr. bow)
diameter of bor	d	according to dowel manufacturer
thickness of the Lift-piece	e	15 mm

picture 21: choice of the dowel lengths 2.25 SL with floor pavement or tile surface



able to picture 21:

dowel type

Liebig B20; UPAT UMV 100 (or UMV 80 for version with base frame bow) or equal dowels of other manufacturers (with authorization)

Drilling depth

a according to dowel manufacturer

min. anchorage depth

b 100 mm (or 80 mm for version with base frame bow)

thickness of concrete

c at least 200 mm (or at least 150 mm for vers. w. base fr. bow)

diameter of bore

d according to dowel manufacturer

thickness of the Lift-piece

with bottom

e+f depending of floor pavement (f = 15 mm)

First security check before installation



to fill in and to leave in this document

kind of check	all right	defect lacking	verification	Remark
Type plate	<input type="checkbox"/>	<input type="checkbox"/>	<input type="checkbox"/>
Short operating instructions.....	<input type="checkbox"/>	<input type="checkbox"/>	<input type="checkbox"/>
Warning designation	<input type="checkbox"/>	<input type="checkbox"/>	<input type="checkbox"/>
Detailed operating instructions.....	<input type="checkbox"/>	<input type="checkbox"/>	<input type="checkbox"/>
Designation Lifting/Lowering	<input type="checkbox"/>	<input type="checkbox"/>	<input type="checkbox"/>
Main switch lockable.....	<input type="checkbox"/>	<input type="checkbox"/>	<input type="checkbox"/>
Function switching off.....	<input type="checkbox"/>	<input type="checkbox"/>	<input type="checkbox"/>
Rotating direction of motor.....	<input type="checkbox"/>	<input type="checkbox"/>	<input type="checkbox"/>
Securing of carrying arm bolts.....	<input type="checkbox"/>	<input type="checkbox"/>	<input type="checkbox"/>
Securing of pads	<input type="checkbox"/>	<input type="checkbox"/>	<input type="checkbox"/>
Construction (deformation, cracking)	<input type="checkbox"/>	<input type="checkbox"/>	<input type="checkbox"/>
Fixed seat of the carrying screws	<input type="checkbox"/>	<input type="checkbox"/>	<input type="checkbox"/>
Condition spindle and carrying nut.....	<input type="checkbox"/>	<input type="checkbox"/>	<input type="checkbox"/>
Smooth running of the lift.....	<input type="checkbox"/>	<input type="checkbox"/>	<input type="checkbox"/>
Stability of the lift.....	<input type="checkbox"/>	<input type="checkbox"/>	<input type="checkbox"/>
Function equalisation control.....	<input type="checkbox"/>	<input type="checkbox"/>	<input type="checkbox"/>
Condition coverings	<input type="checkbox"/>	<input type="checkbox"/>	<input type="checkbox"/>
Condition electrical wiring	<input type="checkbox"/>	<input type="checkbox"/>	<input type="checkbox"/>
Protective conductor	<input type="checkbox"/>	<input type="checkbox"/>	<input type="checkbox"/>
Function test automotive lift with vehicle ..	<input type="checkbox"/>	<input type="checkbox"/>	<input type="checkbox"/>
Condition concrete floor (cracks)	<input type="checkbox"/>	<input type="checkbox"/>	<input type="checkbox"/>
Fixing device.....	<input type="checkbox"/>	<input type="checkbox"/>	<input type="checkbox"/>
Condition bolt	<input type="checkbox"/>	<input type="checkbox"/>	<input type="checkbox"/>

(mark where applicable, in case of verification mark in addition to the first mark!)

security check carried out:

Name, address of the competent.....

Result of the Check:

- Initiation not permitted, verification necessary
- Initiation possible, repair failures until
- No failings, Initiation possible

Signature of the expert:.....

Signature of the operator:.....

If failures must be repaired

Failures repaired at:

Signature of the operator:.....

(Use another form for verification!)

Regular security check



to fill in and to leave in this document

kind of check	all right	defect lacking	verification	Remark
Type plate	<input type="checkbox"/>	<input type="checkbox"/>	<input type="checkbox"/>
Short operating instructions.....	<input type="checkbox"/>	<input type="checkbox"/>	<input type="checkbox"/>
Warning designation	<input type="checkbox"/>	<input type="checkbox"/>	<input type="checkbox"/>
Detailed operating instructions.....	<input type="checkbox"/>	<input type="checkbox"/>	<input type="checkbox"/>
Designation Lifting/Lowering	<input type="checkbox"/>	<input type="checkbox"/>	<input type="checkbox"/>
Main switch lockable.....	<input type="checkbox"/>	<input type="checkbox"/>	<input type="checkbox"/>
Function switching off.....	<input type="checkbox"/>	<input type="checkbox"/>	<input type="checkbox"/>
Rotating direction of motor.....	<input type="checkbox"/>	<input type="checkbox"/>	<input type="checkbox"/>
Securing of carrying arm bolts.....	<input type="checkbox"/>	<input type="checkbox"/>	<input type="checkbox"/>
Securing of pads	<input type="checkbox"/>	<input type="checkbox"/>	<input type="checkbox"/>
Construction (deformation, cracking)	<input type="checkbox"/>	<input type="checkbox"/>	<input type="checkbox"/>
Fixed seat of the carrying screws	<input type="checkbox"/>	<input type="checkbox"/>	<input type="checkbox"/>
Condition spindle and carrying nut.....	<input type="checkbox"/>	<input type="checkbox"/>	<input type="checkbox"/>
Smooth running of the lift.....	<input type="checkbox"/>	<input type="checkbox"/>	<input type="checkbox"/>
Stability of the lift.....	<input type="checkbox"/>	<input type="checkbox"/>	<input type="checkbox"/>
Function equalisation control.....	<input type="checkbox"/>	<input type="checkbox"/>	<input type="checkbox"/>
Condition coverings	<input type="checkbox"/>	<input type="checkbox"/>	<input type="checkbox"/>
Condition electrical wiring	<input type="checkbox"/>	<input type="checkbox"/>	<input type="checkbox"/>
Protective conductor	<input type="checkbox"/>	<input type="checkbox"/>	<input type="checkbox"/>
Function test automotive lift with vehicle ..	<input type="checkbox"/>	<input type="checkbox"/>	<input type="checkbox"/>
Condition concrete floor (cracks)	<input type="checkbox"/>	<input type="checkbox"/>	<input type="checkbox"/>
Fixing device.....	<input type="checkbox"/>	<input type="checkbox"/>	<input type="checkbox"/>
Condition bolt	<input type="checkbox"/>	<input type="checkbox"/>	<input type="checkbox"/>

(mark where applicable, in case of verification mark in addition to the first mark!)

security check carried out:

Name, address of the competent.....

Result of the Check:

Initiation not permitted, verification necessary

Initiation possible, repair failures until

No failings, Initiation possible

Signature of the expert:.....

Signature of the operator:.....

If failures must be repaired

Failures repaired at:

Signature of the operator:.....

(Use another form for verification!)

Extraordinary security check



to fill in and to leave in this document

kind of check	all right	defect lacking	verification	Remark
Type plate	<input type="checkbox"/>	<input type="checkbox"/>	<input type="checkbox"/>
Short operating instructions.....	<input type="checkbox"/>	<input type="checkbox"/>	<input type="checkbox"/>
Warning designation	<input type="checkbox"/>	<input type="checkbox"/>	<input type="checkbox"/>
Detailed operating instructions.....	<input type="checkbox"/>	<input type="checkbox"/>	<input type="checkbox"/>
Designation Lifting/Lowering	<input type="checkbox"/>	<input type="checkbox"/>	<input type="checkbox"/>
Main switch lockable.....	<input type="checkbox"/>	<input type="checkbox"/>	<input type="checkbox"/>
Function switching off.....	<input type="checkbox"/>	<input type="checkbox"/>	<input type="checkbox"/>
Rotating direction of motor.....	<input type="checkbox"/>	<input type="checkbox"/>	<input type="checkbox"/>
Securing of carrying arm bolts.....	<input type="checkbox"/>	<input type="checkbox"/>	<input type="checkbox"/>
Securing of pads	<input type="checkbox"/>	<input type="checkbox"/>	<input type="checkbox"/>
Construction (deformation, cracking)	<input type="checkbox"/>	<input type="checkbox"/>	<input type="checkbox"/>
Fixed seat of the carrying screws	<input type="checkbox"/>	<input type="checkbox"/>	<input type="checkbox"/>
Condition spindle and carrying nut.....	<input type="checkbox"/>	<input type="checkbox"/>	<input type="checkbox"/>
Smooth running of the lift.....	<input type="checkbox"/>	<input type="checkbox"/>	<input type="checkbox"/>
Stability of the lift.....	<input type="checkbox"/>	<input type="checkbox"/>	<input type="checkbox"/>
Function equalisation control.....	<input type="checkbox"/>	<input type="checkbox"/>	<input type="checkbox"/>
Condition coverings	<input type="checkbox"/>	<input type="checkbox"/>	<input type="checkbox"/>
Condition electrical wiring	<input type="checkbox"/>	<input type="checkbox"/>	<input type="checkbox"/>
Protective conductor	<input type="checkbox"/>	<input type="checkbox"/>	<input type="checkbox"/>
Function test automotive lift with vehicle ..	<input type="checkbox"/>	<input type="checkbox"/>	<input type="checkbox"/>
Condition concrete floor (cracks)	<input type="checkbox"/>	<input type="checkbox"/>	<input type="checkbox"/>
Fixing device.....	<input type="checkbox"/>	<input type="checkbox"/>	<input type="checkbox"/>
Condition bolt	<input type="checkbox"/>	<input type="checkbox"/>	<input type="checkbox"/>

(mark where applicable, in case of verification mark in addition to the first mark!)

security check carried out:

Name, address of the competent.....

Result of the Check:

Initiation not permitted, verification necessary

Initiation possible, repair failures until

No failings, Initiation possible

Signature of the expert:.....

Signature of the operator:.....

If failures must be repaired

Failures repaired at:

Signature of the operator:.....

(Use another form for verification!)